



Specifications: CM31-EZ

Tile bridge included

System Type	3 inch full-range, in-ceiling (20 watt transformer for 25/70.7/100-volt or transformer bypass position)
Impedance (nominal) ¹	8 ohm
Sensitivity dB @ 2.83 V/1 m	84.0 dB
Sensitivity dB @ 1 W/1 m ²	84.0 dB
Frequency Response (-3 dB) ³	140 Hz - 12 kHz
Frequency Response (-10 dB) ³	100 Hz - 18 kHz
Max. Program Power ⁴	40 W
Max. Continuous Power RMS ⁵	20 W
Max. Power SPL @ 1 m ⁶	97.0 dB
Coverage Angle (-6 dB @ 2 kHz)	180°
Coverage Angle (-6 dB @ 10 kHz)	130°
Coverage Angle (averaged from 2 to 10 kHz)	135°
Directivity Factor (Q)	N/A (averaged 100Hz - 10kHz), N/A (2kHz)
Directivity Index (DI) dB	N/A (averaged 100Hz - 10kHz), N/A (2kHz)
Tap Selector (transformer accessory only)	Six-position rotary switch or transformer bypass position
Transducer - Full-Range Driver	76.1 mm (3.0 in.) Polypropylene driver with butyl rubber surround
Enclosure Material	ABS baffle, steel backcan
Grille	Corrosion-resistant, powder-coated aluminum
Inputs	Hardwire lead
Colors	Black or white
Backcan Diameter	139.1 mm (5.5 in.)
Backcan Height	89.4 mm (3.5 in.)
Visible Height	15.2 mm (0.6 in.)
Visible Diameter	160.6 mm (6.3 in.)
Weight	1.4 kg (3.1 lbs.)
Shipping Weight	1.8 kg (4.0 lbs.)
Packaging	One per box
Included Accessories	Tile Bridge, conduit connector, paint mask and wire nuts
Optional Accessories	Pre-construction bracket (AC-CM3-PCB), 10 inch powered subwoofer (SM1001p)
Regulatory - UL	UL 1480 (UEAY) and 2043 approved
Regulatory - CE	Approved
RoHS	Approved
	Transformer Taps

¹ Impedance listed per IEC 60268-5 with a minimum less than 80% the nominal impedance

² 1 W 1 m sensitivity determined using nominal impedance

³ Frequency response measured in half or full space as dictated by speaker mounting configuration

⁴ Max program power is 3 dB above max continuous power

⁵ Continuous power rating, EIA-426-B test

⁶ Max output based on max continuous power

	70.7 V Output		100 V Output		25 V Output	
	20 W	100.0 dB	20 W	100.0 dB	5 W	94.0 dB
	10 W	97.0 dB	10 W	97.0 dB	2.5 W	91.0 dB
	5 W	94.0 dB	5 W	94.0 dB	1.25 W	88.0 dB
	2.5 W	91.0 dB	2.5 W	91.0 dB	0.63 W	85.0 dB
	1.25 W	88.0 dB			0.32 W	82.0 dB

Preliminary Technical Information

- One 3 inch (76.2 mm) full-range high-extrusion, high-fidelity polypropylene driver with butyl rubber surround.
- Weatherized components for indoor/outdoor applications.
- Shallow 3.5 inch (89.4 mm) deep all-steel backcan with integrated driver and baffle configuration.
- Ultra-compact design with a total visible footprint of less than 6.3 inch (160.6 mm) diameter.
- Rapid installation, blind-mount, fixed-wing mounting mechanism with constant tension design affixing to wall thicknesses ranging from 0.1 in. (2.5 mm) to 1.5 in. (38.1 mm).
- Corrosion-resistant, powder-coated aluminum grille with snap fit attachment.
- UL 1480 (UEAY) and 2043 approved.
- High quality black or white paint finish.
- Included accessories: Tile bridge.
- Optional accessories: Pre-construction bracket (AC-CM3-PCB) and 10-inch powered subwoofer (SM1001p).

Description

The CM31-EZ is a premium full-range 3-inch in-ceiling speaker for applications requiring 8 ohm or distributed audio solutions. The CM31-EZ incorporates low profile grille with a total visible footprint of 6.3 inch diameter and an integrated backcan and driver design for ultra compact in-ceiling installations. The in-ceiling speaker includes a six-position tap switch with a transformer bypass position. A tile bridge and mounting hardware are included and feature a fast and secure constant tension SpeedWing™ mounting system. The CM31-EZ incorporates weatherized components for indoor/outdoor applications.

Applications

Engineered for rapid installation and low profile mounting for smaller venues, the CM31-EZ is ideal for retail, restaurants, conference rooms, educational facilities or any setting where full-range intelligibility, low profile design and in-ceiling installation ease are paramount. For additional bass response down to 41 Hz (-10 dB), the SM1001p powered 10-inch subwoofer may be incorporated.



Patented SoundTube Technologies

SoundTube Entertainment and the MSE Audio Group constantly develop new technologies which enhance audio product performance. SoundTube Entertainment innovations are protected by multiple U.S. and international patents, which explicitly cover SoundTube dome, enclosure and dispersion technologies. The MSE Audio Group actively defends its patents in order to protect SoundTube resellers and end-users.

Technical Data and Specification Tools

Technical Data

SoundTube Entertainment strives to provide complete and effective technical information and data to dealers, engineers and designers. All data are available from SoundTube Entertainment or at www.soundtube.com.

Technical data and downloads include:

EASE™ data – 3-D polar plots.

EASE™ Address – 2-D modeling for distributed systems

Autodesk® Revit® software

Tech Sheets – Technical information and architectural specs for system engineers

SoundTubeSPEC™ – Proprietary speaker placement software

Acquisition & Verification

All data for SoundTube speakers are independently collected from and verified by NWAALabs (www.nwaalabs.com) using their proprietary MACH testing system. All data are collected and analyzed according to ASTM, ISO and AES standards using EASERA, TEF and MLSSA. Full balloon data including both phase and magnitude is compiled into a variety of formats including EASE 4.x, GLL and CLF.

Architectural Specifications

The loudspeaker transducer shall consist of one full-range 76.2 mm (3.0 in.) polypropylene cone with butyl rubber surround.

Performance specifications for a typical production unit shall be as follows: Useable frequency response shall extend from 100

Hz – 18 kHz (-10 dB). Measured sensitivity (2.83 volt input, 1 meter) shall be at least 84.0 dB. The speaker shall have a nominal impedance of 8 ohms. The speaker shall be available for 25-, 70.7- and 100-volt modes and shall include a six-position tap switch with a transformer bypass position. Rated power capacity shall be at least 20 watts continuous (RMS) and conform to EIA-426-B. Maximum continuous power output at 1 meter shall be 97.0 dB.

Installation for the speaker shall be by two-screw, blind-mount, constant tension fixed-wing assembly and shall attach to ceiling thicknesses ranging from 2.5 mm (0.1 in.) to 38.1 mm (1.5 in.). A secondary attachment point has been included on the back of the unit. The fixed wing assembly shall be constructed of steel. The external wiring shall be by hardwire lead and the speaker shall include a UL-listed conduit connector.

The maximum backcan dimensions shall be no more than 139.1 mm (5.5 in.) in diameter by 89.4 mm (3.5 in.) in height. The maximum visible dimension shall be no more than 15.2 mm (0.6 in.) in height by 160.6 mm (6.3 in.) in diameter.

The system shall be for indoor/outdoor applications.

The enclosure shall be constructed of steel. The grille shall be constructed of powder-coated aluminum for lasting performance and affix to the speaker baffle via snap fit.

The system shall be the CM31-EZ for low- or high-impedance applications.

SoundTube Entertainment

6430 North Business Park Loop
Park City, Utah 84098
Phone 435.647.9555
Fax 435.647.9666
Toll Free 800.647.TUBE
www.soundtube.com

All SoundTube products come with a 5-year limited warranty.



Graphs and Plots

Frequency Response

Phase/Impedance Response

Vertical Beamwidth (-6 dB)

Directivity Index (DI)



Polar Plots

———— Horizontal
 - - - - - Vertical

125 Hz

250 Hz

500 Hz

1,000 Hz

2,000 Hz

4,000 Hz

8,000 Hz

10,000 Hz

Technical data, EASE™ plots, SoundTubeSPEC™ software and product downloads available at www.soundtube.com

Mechanical Drawings

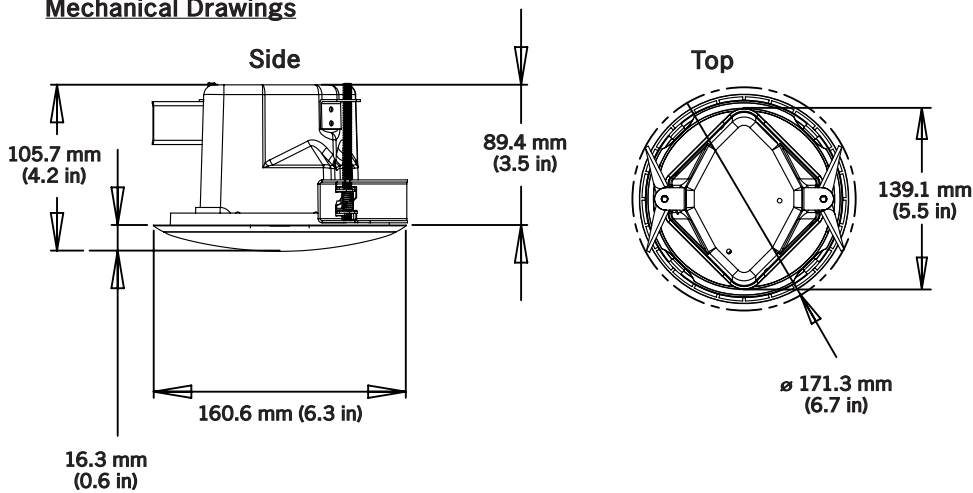

Minimum/Maximum Ceiling Thickness

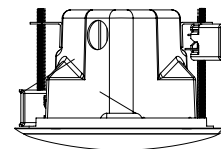

Min. 2.5 mm (0.1 in)
 Max. 38.1 mm (1.5 in)

Optional Accessories

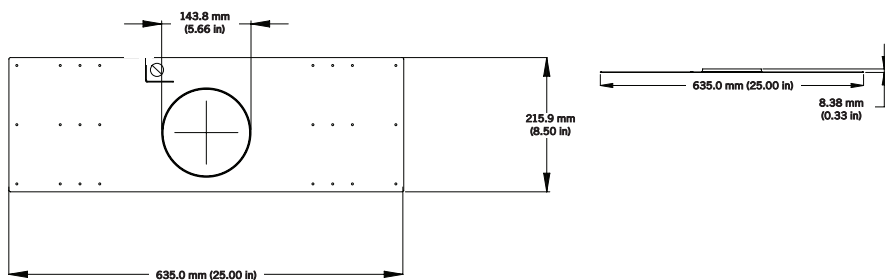

Included Accessories

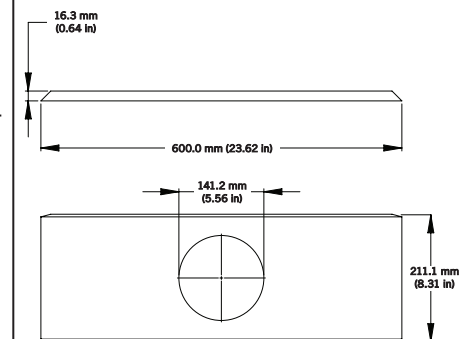

Pre-Construction Bracket (AC-CM3-PCB)

Tile Bridge

SoundTube Entertainment manufactures a complete line of speakers for:
Open-Ceiling • In-Ceiling • Surface-Mount • Outdoor • Sound-Focusing

All SoundTube products are designed and engineered in the USA.