



Specifications: CM600i

Tile bridge included

System Type	6.5-inch, coaxial, in-ceiling, ported (33-watt transformer for 25/70.7/100-volt or transformer bypass)
Impedance (nominal) ¹	8 ohm
Sensitivity dB @ 2.83 V / 1 m	88.0 dB
Sensitivity dB @ 1 W / 1 m ²	88.0 dB
Frequency Response (-3 dB) ³	69 Hz - 22 kHz
Frequency Response (-10 dB) ³	52 Hz - 22 kHz
Max. Program Power ⁴	180 W
Max. Continuous Power RMS ⁵	90 W
Max. Power SPL @ 1 m ⁶	107.5 dB
Coverage Angle (-6 dB @ 2 kHz)	135°
Coverage Angle (-6 dB @ 10 kHz)	100°
Coverage Angle (averaged from 2 to 10 kHz)	110°
Directivity Factor (Q)	4.0 (averaged from 100 Hz - 10 kHz); 5.4 (2 kHz)
Directivity Index (DI)	5.6 (averaged 100 Hz - 10 kHz); 7.3 (2 kHz)
Tap Selector	Six-position rotary switch with transformer bypass
Transducer - Low-Frequency Driver	165 mm (6.5 in.) Polypropylene cone, butyl rubber surround
Transducer - High-Frequency Driver	25 mm (1.0 in.) Convex titanium tweeter with waveguide
Low-Frequency Voice Coil	25.4 mm (1.0 in.)
Crossover Frequency	3.0 kHz
Network Type: Low Pass	12 dB per octave, 2nd order
Network Type: High Pass	12 dB per octave, 2nd order
Enclosure Material	Drawn aluminum backcan with ABS baffle
Motor-board	Cast aluminum
Grille	Steel with powder-coat finish
Inputs	Four-pin, 5.08 mm Euroblock for individual or daisy chain connection
Colors	Black or white
Backcan Diameter	296.7 mm (11.68 in.)
Backcan Height	201.7 mm (7.94 in.)
Visible Diameter	374.9 mm (14.76 in.)
Visible Height	27.4 mm (1.08 in.)
Mounting Hole Diameter	323.9 mm (12.75 in.)
Min - Max Ceiling Thickness	6.4 mm (0.25 in.) - 48.5 mm (1.91 in.)
Weight	4.6 kg (10.1 lbs.)
Shipping Weight	15.5 kg (34.2 lbs.)
Packaging	Two per box
Included Accessories	Tile bridge, conduit plate, Euroblock connector and installation aid
Optional Accessories	Pre-construction bracket (AC-CM6-PCB), junction box (AC-CMi-JBOX)
Regulatory - UL	UL 2043 and 1480 (UEAY) Approved
Regulatory - CE	Approved
RoHS	Approved

Transformer Taps

	70.7 V	Output	100 V	Output	25 V	Output
¹ Impedance listed per IEC 60268-5 with a minimum less than 80% the nominal impedance						
² 1 W 1 m sensitivity determined using nominal impedance	33 W	103.0 dB	33 W	103.0 dB	5 W	95.0 dB
³ Frequency response measured in half or full space as dictated by speaker mounting configuration	17 W	100.5 dB	17 W	100.5 dB	2.5 W	92.0 dB
⁴ Max program power is 3 dB above max continuous power	9 W	97.5 dB	9 W	97.5 dB	1.3 W	89.0 dB
⁵ Continuous power rating, EIA-426-B test	6 W	96.0 dB	6 W	96.0 dB	0.63 W	86.0 dB
⁶ Max output based on max continuous power	3 W	93.0 dB				

Key Features

- Patented BroadBeam® waveguide technology delivers a consistent dispersion pattern for maximum intelligibility and edge-to-edge coverage (2 to 10 kHz, independently verified).
- One 6.5 inch (165 mm) polypropylene woofer and one 1.0 inch (25 mm) convex aluminum tweeter with FerroFluid cooling mounted to a proprietary cast-aluminum motor-board and heat sink.
- Rapid-installation, blind-mount, fixed-wing mounting mechanism with constant-tension design affixing to ceiling thicknesses ranging from 0.25 inch (6.4 mm) to 1.69 inch (42.9 mm).
- Easy-access six-position selectable tap switch for 25-, 70.7- and 100-volt applications with a transformer bypass position.
- Separate tool-free magnetic grille and bezel assembly with integrated safety cable for ease of install and in-field painting.
- Steel grille with protective powder-coated finish for lasting durability.
- Average sensitivity of 88 dB offers high-output capabilities and reduced amplification costs.
- UL 1480 (UEAY) and 2043 approved.
- High-quality black or white paint finish. Custom paint colors optional.
- Included accessories: Tile bridge, Euroblock connector, paint mask, conduit plate.
- Optional accessories: Color-coded (purple) pre-construction bracket (AC-CM6-PCB), junction box (AC-CMi-JBOX).

Description

The CM600i is a 6.5-inch, two-way, blind-mount in-ceiling speaker design that delivers extended low-end response (52 Hz) and optimal off-axis performance (2 to 10 kHz, independently verified). SoundTube's proprietary BroadBeam® waveguide tweeter system delivers consistent high-performance audio across the operating bandwidth. The CM600i speaker design incorporates a low-profile grille, proprietary motor-board and six-position tap switch with transformer bypass position. Mounting hardware is included and features a fast and secure constant-tension, fixed-wing mounting system.

Applications

Designed for in-ceiling background to foreground SPL applications, the CM600i



delivers a broad dispersion pattern and high sensitivity. The CM600i is ideal for nightclubs, bars, fitness centers, hotels, airports, convention centers, casinos, corporate venues, churches and other in-ceiling applications requiring background to foreground SPL. For applications where additional bass is required, SoundTube's CM1001d-T 10-inch subwoofer provides low-end response down to 41 Hz.

BroadBeam[®] Wide Dispersion Technology

SoundTube's proprietary BroadBeam[®] technology incorporates a high-frequency waveguide mated to a 1-inch convex titanium tweeter. The BroadBeam[®] high-frequency waveguide delivers a consistent dispersion pattern across the upper registers of the frequency spectrum (2 to 10 kHz, independently verified). The result is an audio system requiring fewer speakers with higher intelligibility, offering reduced power needs, shorter installation time and cost savings on shipping and labor.

Patented SoundTube Technologies

SoundTube Entertainment and the MSE Audio Group constantly develop new technologies which enhance audio product performance. SoundTube Entertainment innovations are protected by multiple U.S. and international patents, which explicitly cover SoundTube dome, enclosure and dispersion technologies. The MSE Audio Group actively defends its patents in order to protect SoundTube resellers and end-users.

Technical Data and Specification Tools

Technical Data

SoundTube Entertainment strives to provide complete and effective technical information and data to dealers, engineers and designers. All data are available from SoundTube Entertainment or at www.soundtube.com.

Technical data and downloads include:

EASE[™] data – 3-D polar plots.

EASE[™] Address – 2-D modeling for distributed systems

Autodesk[®] Revit[®] software

Tech Sheets – Technical information and architectural specs for system engineers

SoundTubeSPEC[™] – Proprietary speaker placement software

Acquisition and Verification

All data for SoundTube speakers are independently collected from and verified by NWA Labs (www.nwaalabs.com) using their proprietary MACH testing system. All data are collected and analyzed according to ASTM, ISO and AES standards using EASERA, TEF and MLSSA. Full balloon data including both phase and magnitude is compiled into a variety of formats including EASE 4.x, GLL and CLF.

Architectural Specifications

The loudspeaker shall consist of a 165 mm (6.5 in.) low-frequency transducer and a 25 mm (1.0 in.) high-frequency transducer with a crossover network installed in the ported enclosure. The low-frequency voice coil diameter shall be 25 mm (1.0 in.).

Performance specifications of a typical production unit shall be as follows: Useable frequency response shall extend from 52 Hz – 22 kHz (-10 dB, half space). Measured sensitivity (2.83-volt input, 1 meter) shall be at least 88 dB. The speaker shall have a nominal impedance of 8 ohms. The speaker shall be available for 25-, 70.7- and 100-volt modes and shall include a six-position tap switch with a transformer bypass position. The frequency-dividing network shall have a crossover frequency of 3 kHz with slopes of 12 dB per octave (2nd order) for both low- and high-pass filters. Rated power capacity shall be at least 90 watts continuous (RMS) and conform to EIA-426-B testing. Maximum continuous output at 1 meter shall be 107.5 dB.

Installation for the speaker shall be by two-screw, blind-mount, constant-tension winged assembly and shall attach to ceiling thicknesses ranging from 6.4 mm (0.25 in.) to 48.5 mm (1.91 in.). The fixed-wing assembly shall be constructed of steel. A secondary attachment point has been included on the back of the unit. The external wiring input connector shall be a four-pin, 5.08 mm Euroblock for 8 ohm or distributed systems and shall accept

from 10 – 22-gauge wire.

The maximum backcan dimensions shall be no more than 201.7 mm (7.94 in.) in height by 296.7 mm (11.68 in.) in diameter. The maximum visible dimensions shall be no more than 27.5 mm (1.08 in.) in height by 375 mm (14.76 in.) in diameter. The backcan shall be constructed of aluminum.

The system shall include a 21-gauge galvanized steel support backing plate (tile bridge) to reinforce the ceiling material and tile support rails. The maximum tile bridge dimensions shall be no more than 600.1 mm (23.62 in.) in length by 428.2 mm (16.86 in.) in width and 10.4 mm (0.41 in.) in height with 325.1 mm (12.80 in.) cutout for speaker mounting.

The grille shall be constructed of powder-coated steel with an ABS bezel for lasting performance. The affixed grille and bezel shall be mounted to the speaker enclosure (backcan) via neodymium magnets and included safety leash. Also included is a paint mask/installation aid for in-field painting (also serves as a handhold during mounting).

The unit has an optional color-coded (purple) pre-construction bracket (AC-CM6-PCB) that shall be compatible with an optional junction box (AC-CMi-JBOX). A 2-foot, 18-gauge hardwire lead, conduit connector and Euroblock connector shall be included with the junction box. The maximum dimensions of the pre-construction bracket shall be no more than 635 mm (25.0 in.) in length by 457.2 mm (18.0 in.) in width and 127 mm (5.0 in.) in height (includes affixed junction box) with a 326.1 mm (12.85 in.) cutout for speaker mounting.

The system shall be the SoundTube CM600i for both low- and high-impedance applications.

SoundTube Entertainment

6430 North Business Park Loop
Park City, Utah 84098
Phone 435.647.9555
Fax 435.647.9666
Toll Free 800.647.TUBE
www.soundtube.com

All SoundTube products come with a 5-year limited warranty.

Graphs and Plots

Frequency Response

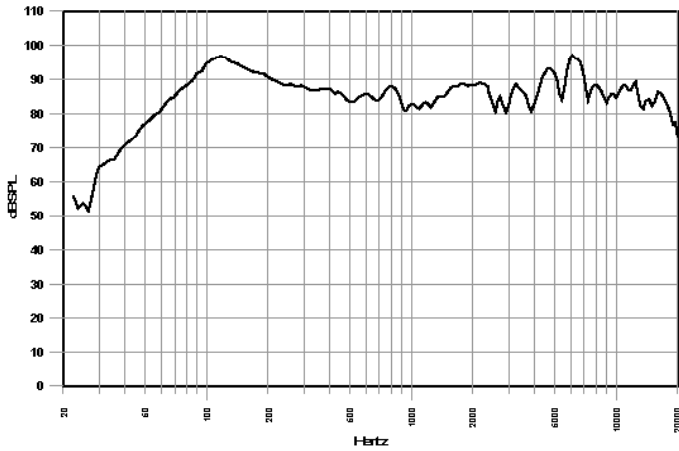

Phase/Impedance Response

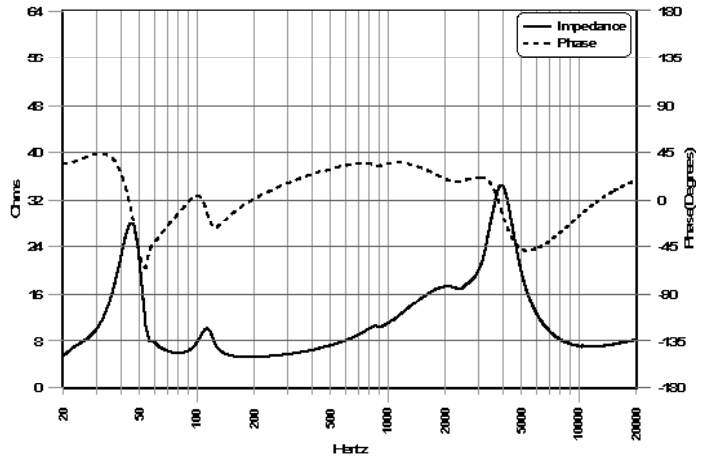

Vertical Beamwidth (-6 dB)

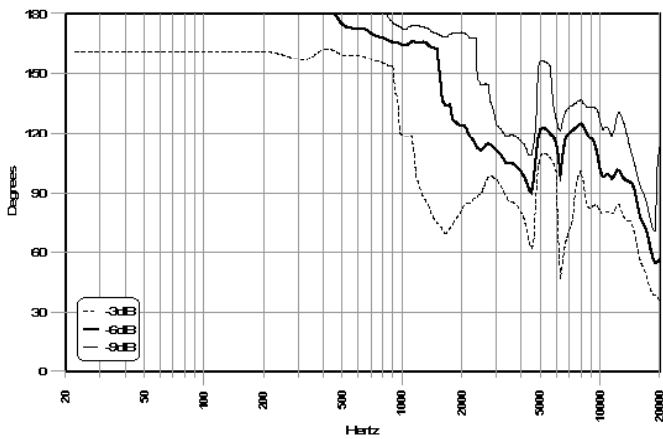

Directivity Index (DI)

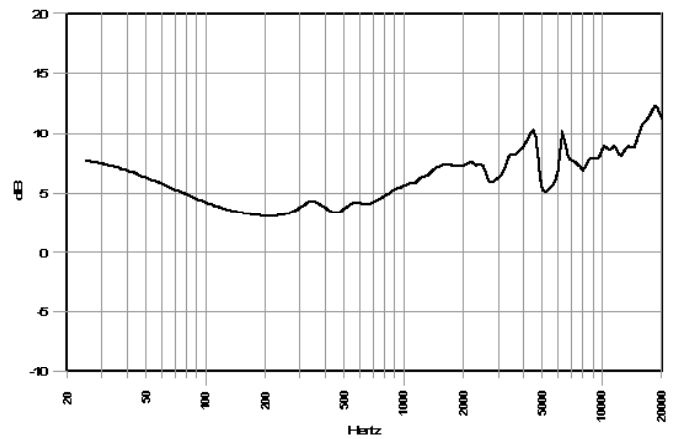

Polar Plots

— Horizontal
 - - - Vertical

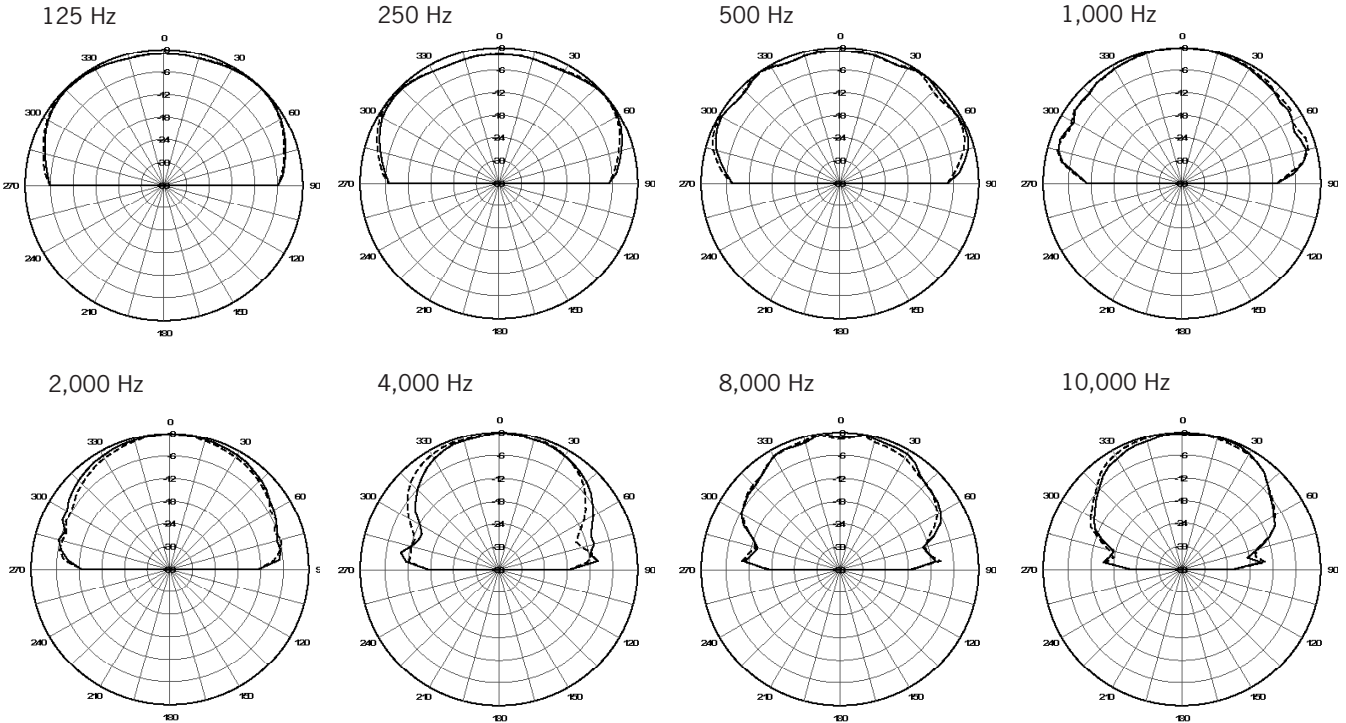

Technical data, EASE™ plots, SoundTubeSPEC™ software and product downloads available at www.soundtube.com

Mechanical Drawings

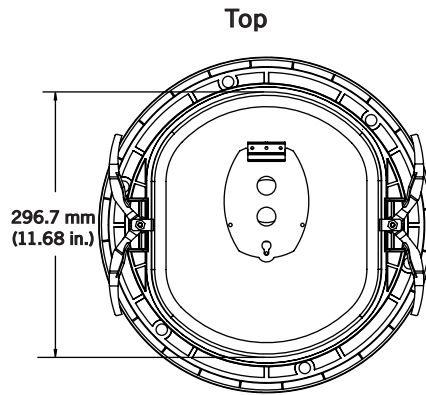
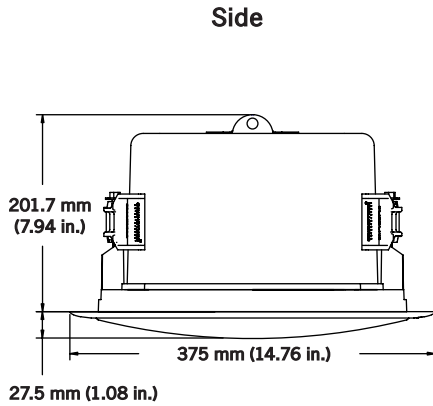

Minimum/Maximum Ceiling Thickness

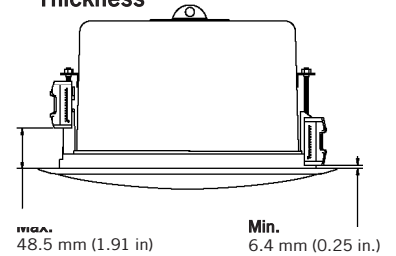

Included Accessories

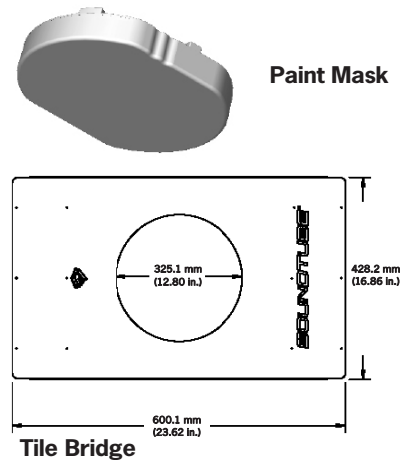

Optional Accessories

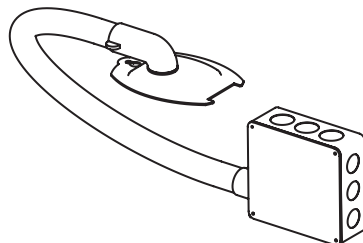
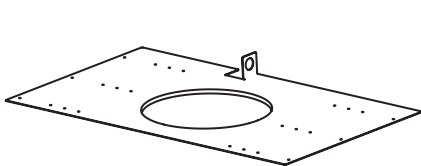

Pre-Construction Bracket (AC-CM8-PCB)

Junction Box (AC-CMi-JBOX)

SoundTube Entertainment manufactures a complete line of speakers for:
Open-Ceiling • In-Ceiling • Surface-Mount • Outdoor • Sound-Focusing