



### Specifications: RF31-EZ

System Type	3-inch, full-range, in-wall, raw frame
Impedance (nominal) <sup>1</sup>	8 ohm
Sensitivity dB @ 2.83 V/1 m	86.0 dB
Sensitivity dB @ 1 W/1 m <sup>2</sup>	86.0 dB
Frequency Response (-3 dB) <sup>3</sup>	150 Hz - 22 kHz
Frequency Response (-10 dB) <sup>3</sup>	100 Hz - 22 kHz
Max. Program Power <sup>4</sup>	40 W
Max. Continuous Power RMS <sup>5</sup>	20 W
Max. Power SPL @ 1 m <sup>6</sup>	99 dB
Coverage Angle (-6 dB @ 2 kHz)	N/A
Coverage Angle (-6 dB @ 10 kHz)	N/A
Coverage Angle (averaged from 2 to 10 kHz)	105°
Directivity Factor (Q)	N/A (averaged 100 Hz - 10 kHz); 4.6 (2 kHz)
Directivity Index (DI)	N/A (averaged 100 Hz - 10 kHz); 6.6 dB (2 kHz)
Transducer - Full-Range Driver	76.1 mm (3.0 in.) Polypropylene driver with butyl rubber surround
Enclosure Material	ABS baffle
Grille	ABS bezel with perforated aluminum grille
Inputs	Bare leads, wire nuts
Colors	White (paintable grille)
Depth	53.3 mm (2.1 in.)
Visible Height	120.7 mm (4.75 in.)
Visible Width	120.7 mm (4.75 in.)
Weight	0.7 kg (1.5 lbs.)
Shipping Weight	0.9 kg (2.0 lbs.)
Packaging	One per box
Included Accessories	White snap-on aluminum grille, paint mask, two wire nuts, and four stainless steel mounting screws
Optional Accessories	Theft-resistant stainless steel grille (AC-RF31-TRG) and 10-inch powered subwoofer (SM1001p)
Regulatory - CE	Approved
Regulatory - UL	UL 1480 (UEAY) listed
RoHS	Approved

<sup>1</sup> Impedance listed per IEC 60268-5 with a minimum less than 80% the nominal impedance

<sup>2</sup> 1 W 1 m sensitivity determined using nominal impedance

<sup>3</sup> Frequency response measured in half or full space as dictated by speaker mounting configuration

<sup>4</sup> Max program power is 3 dB above max continuous power

<sup>5</sup> Continuous power rating, EIA-426-B test

<sup>6</sup> Max output based on max continuous power

### Key Features

- One 3-inch full-range high-excursion, weather-resistant, high-fidelity polypropylene driver with butyl rubber surround and neodymium magnet.
- Ultra-compact design with a total visible footprint of 4.75-inch square.
- Weatherized components for indoor/outdoor applications.
- Corrosion-resistant, powder-coated aluminum grille with snap fit attachment.
- Rapid installation into dual-gang junction box using four included stainless steel screws (junction box not included).
- UL 1480 (UEAY) listed.
- High-quality white paint finish grille.
- Included accessories: Paintable white aluminum snap-on grille, paint mask, four stainless steel mounting screws, and two wire nuts.
- Optional accessories: Theft-resistant stainless steel grille (AC-RF31-TRG) and 10-inch powered subwoofer (SM1001p).

### Description

The RF31-EZ is a premium full-range 3-inch speaker for applications requiring 8 ohm audio solutions. The RF31-EZ incorporates a low-profile grille with a total visible footprint of 4.75-inch square for ultra-compact installations. The RF31-EZ mounts in most dual-gang junction boxes. All components in the RF31-EZ are completely weatherized for indoor and outdoor applications.

### Applications

Engineered for easy installation indoors and out, the RF31-EZ is ideal for any installation requiring big sound including retail outlets, hospitals, government facilities, houses of worship, restaurants, schools, and more. Weatherized components make the RF31-EZ perfect for gardens, parks, pool areas, or even a kitchen backsplash. The optional theft-resistant grill makes the RF31-EZ ideal for high risk installations including schools, correctional facilities, transportation facilities, hallways, and any location where the public might contact the speaker. For additional bass response down to 20 Hz (-10 dB), the SM1001p powered 10-inch subwoofer may be used.



## Patented SoundTube Technologies

SoundTube Entertainment and the MSE Audio Group constantly develop new technologies which enhance audio product performance. SoundTube Entertainment innovations are protected by multiple U.S. and international patents, which explicitly cover SoundTube dome, enclosure and dispersion technologies. The MSE Audio Group actively defends its patents in order to protect SoundTube resellers and end-users.

## Technical Data and Specification Tools

### Technical Data

SoundTube Entertainment strives to provide complete and effective technical information and data to dealers, engineers and designers. All data are available from SoundTube Entertainment or at [www.soundtube.com](http://www.soundtube.com).

Technical data and downloads include:

EASE™ data – 3-D polar plots.

EASE™ Address – 2-D modeling for distributed systems

Autodesk® Revit® software

Tech Sheets – Technical information and architectural specs for system engineers

SoundTubeSPEC™ – Proprietary speaker placement software

### Data Acquisition

All data for SoundTube speakers are independently collected from and verified by NWA Labs ([www.nwaalabs.com](http://www.nwaalabs.com)) using their proprietary MACH testing system. All data are collected and analyzed according to ASTM, ISO and AES standards using EASERA, TEF and MLSSA. Full balloon data including both phase and magnitude are compiled into a variety of formats including EASE 4.x, GLL and CLF.

## Architectural Specifications

The loudspeaker transducer shall consist of one full-range 76.2 mm (3.0 in.) polypropylene cone with butyl rubber surround and neodymium magnet.

Performance specifications for a typical production unit shall be as follows:

Useable frequency response shall extend from 100 Hz - 22 kHz (- 10 dB). Measured sensitivity (2.83 volt input, 1 meter) shall be at least 86.0 dB. The speaker shall have a nominal impedance of 8 ohms. Rated power capacity shall be at least 20 watts continuous (RMS) and conform to EIA-426-B. Maximum continuous power output at 1 meter shall be 99 dB.

Installation for the RF31-EZ shall be by four stainless steel screws mounted to a new construction (and some retrofit) dual-gang junction box (junction box not included). The external wiring shall be by bare wire leads and wire nuts.

The system shall be for indoor/outdoor applications.

The grille shall be constructed of powder-coated aluminum for lasting performance and affix to the speaker baffle via snap fit. For theft prevention and durability, an optional stainless steel grille with stainless steel one-way screws is available (AC-RF31-TRG).

The maximum depth shall be no more than 53.3 mm (2.1 in.). The maximum visible dimension shall be no more than 120.7 mm (4.75 in.) in height by 120.7 mm (4.75 in.) in width.

The system shall be the RF31-EZ for low-impedance applications.

## SoundTube Entertainment

6430 Business Park Loop Road

Park City, Utah 84098

Phone 435.647.9555

Fax 435.647.9666

Toll Free 800.647.TUBE

[www.soundtube.com](http://www.soundtube.com)

**All SoundTube products come with a 5-year limited warranty.**

---

---

**RF31-EZ**

**Raw Frame Speaker-**

Preliminary Technical Information for System Engineers



**SOUNDTUBE**  
ENTERTAINMENT

---

**Graphs and Plots**

**Frequency Response**

**Phase/Impedance Response**

---

**Vertical Beamwidth (-6 dB)**

**Directivity Index (DI)**

---

# RF31-EZ

## Raw Frame Speaker

Preliminary Technical Information for System Engineers



**SOUNDTUBE**  
ENTERTAINMENT

### Polar Plots

———— Horizontal  
----- Vertical

125 Hz

250 Hz

500 Hz

1,000 Hz

2,000 Hz

4,000 Hz

8,000 Hz

10,000 Hz

Technical data, EASE™ plots, SoundTubeSPEC™ software and product downloads available at [www.soundtube.com](http://www.soundtube.com)

### Mechanical Drawings

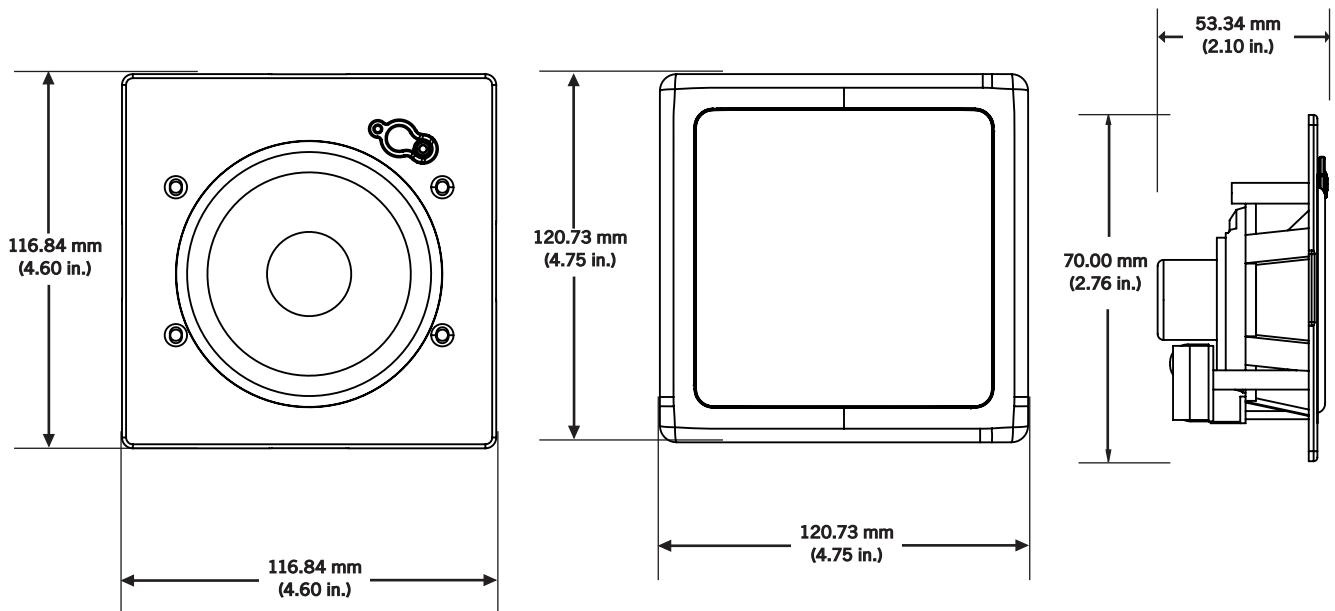

SoundTube Entertainment manufactures a complete line of speakers for:  
**Open-Ceiling • In-Ceiling • Surface-Mount • Outdoor • Sound-Focusing**

All SoundTube products are designed and engineered in the USA.