

CM1001d-T

In-Ceiling Subwoofer
 Technical Information for System Engineers



Specifications: CM1001d-T

Tile bridge included

System Type	10-inch subwoofer, in-ceiling, ported (150-watt transformer for 25/70.7/100-volt or voice-coil-direct)
Impedance (nominal) ¹	4 ohm
Sensitivity dB @ 2.83 V/1 m	92.0 dB
Sensitivity dB @ 1 W/1 m ²	92.0 dB
Frequency Response (-3 dB) ³	55 Hz - 118 Hz
Frequency Response (-10 dB) ³	41 Hz - 224 Hz
Max. Program Power ⁴	300 w
Max. Continuous Power RMS ⁵	150 w
Max. Power SPL @ 1 m ⁶	114.0 dB
Low-Frequency Driver	254 mm (10 in.) Polypropylene cone, butyl rubber surround
Low-Frequency Voice Coil	35.0 mm (1.38 in.)
Crossover Frequency	100 Hz
Low-Pass Filter	6 dB per octave, 1st order
Enclosure Material	Drawn steel backcan with ABS baffle
Motor Board	N/A
Grille	Powder coated steel with integrated ABS baffle
Inputs	Four-pin, 5 mm Euroblock for individual or daisy chain connection
Colors	Black or white
Backcan Height	299.0 mm (11.77 in.)
Visible Diameter	374.9 mm (14.76 in.)
Visible Height	27.4 mm (1.08 in.)
Mounting Hole Diameter	323.9 mm (12.75 in.)
Min. Ceiling Thickness	6.4 mm (0.25 in.)
Max. Ceiling Thickness	42.9 mm (1.69 in.)
Weight	12.3 kg (27.0 lb.)
Shipping Weight	14.5 kg (32.0 lb.)
Included accessories	Tile bridge, Euroblock connector, paint mask, restraint cable
Optional accessories	Pre-construction bracket (AC-CM8-PCB), junction box (AC-CMi-JBOX)
Packaging	One per box
Regulatory - CE	Approved
Regulatory - UL	UL 1480- and 2043-Approved

Key Features

- One 254 mm (10 in.) polypropylene cone with a butyl rubber surround on a reinforced ABS baffle.
- Extra-large SoundTube-specific 12.9 liter steel DeepCan™ (11.77-inch depth) for quality bass response.
- Baffle-mounted, flared and tuned port for maximum efficiency and frequency response.
- High output (114 dB SPL) and maximum efficiency with an accentuated 70 Hz peak to maximize listener's low-frequency experience.
- Includes an easy-access five-position tap switch for 25/70.7/100-volt and voice-coil-direct settings, allowing for easy ordering, stocking and installation.
- Incorporates a powder-coated steel grille for lasting durability plus a tool-free seismic strap for easy installation.
- cUL 1480 and 2043, CE (EMC Directive 89/366/EEC, EN55020, EN55013) approved.
- Rapid-installation, blind-mount, fixed-wing mounting mechanism with constant-tension design affixing to ceiling thicknesses ranging from 0.25 in. (6.4 mm) to 1.69 in. (42.9 mm).
- Included accessories: Color-coded (purple) tile bridge, grille, UL-rated cover plate, four-pin Euroblock, paint shield and restraint cable.
- Optional accessories: Color-coded (purple) pre-construction bracket (AC-CM8-PCB), junction box (AC-CMi-JBOX).
- High-quality black or white painted finish. Custom colors available.

Description

The CM1001d-T is a 10-inch, blind-mount, in-ceiling subwoofer tuned for maximum output and performance across the operating bandwidth. By incorporating a 10-inch polypropylene woofer and a butyl rubber surround in a tuned and ported enclosure, this speaker delivers maximum low-frequency response (41 Hz – 224 Hz, -10 dB) and high SPL (114 dB). For added low-end punch, SoundTube

Transformer Taps

70.7 V Output		100 V Output		25 V Output	
150 W	114.0 dB	150 W	114.0 dB	19 W	105.0 dB
75 W	111.0 dB	75 W	111.0 dB	9.5 W	102.0 dB
38 W	108.0 dB	38 W	108.0 dB	4.8 W	99.0 dB
19 W	105.0 dB			2.4 W	96.0 dB

¹ Impedance listed per IEC 60268-5

² 1 W/1 m sensitivity determined using nominal impedance

³ Frequency response measured in half or full space as dictated by speaker mounting configuration

⁴ Max program power is 3 dB above max continuous power

⁵ Continuous power rating, EIA-426-B test

⁶ Max output based on max continuous power

⁷ Max useable SPL based on testing by NWA Labs



has incorporated an oversized enclosure and tuned, flared port.

Mounting hardware is included and features a constant-tension fixed-wing mounting system with a 21-gauge "full-metal" steel tile bridge, ensuring rapid and secure installation in any sheetrock or drop-tile application. Restraint cable included for easier installation. For easy ordering, stocking and installation, the CM1001d-T includes a color-coded (purple) tile bridge and ships with a five-position tap switch for 25-, 70.7- and 100-volt applications with voice-coil-direct position.

Applications

The CM1001d-T is a background to foreground subwoofer for installations where high quality, true bass response and rapid installation are critical variables. Aerobic rooms, retail, restaurants, night-clubs, hotels, bars, theme parks, arenas, ballrooms and churches are all ideal fits for the CM1001d-T. Because overall system design is a critical component of subwoofer integration, SoundTube recommends incorporating a DSP system with an active crossover to maximize the subwoofer integration and overall system performance. Tuning the system based on room acoustics and loudspeaker selection will result in smooth response and reduced subwoofer localization.

Patented SoundTube Technologies

SoundTube Entertainment and the MSE Audio Group constantly develop new technologies which enhance audio product performance. SoundTube Entertainment innovations are protected by multiple U.S. and international patents, which explicitly cover SoundTube dome, enclosure and dispersion technologies. The MSE Audio Group actively defends its patents in order to protect SoundTube resellers and end-users.

Technical Data and Specification Tools

Technical Data

SoundTube Entertainment strives to provide complete and effective technical information and data to dealers, engineers and designers. All data are available from SoundTube Entertainment or at www.soundtube.com and includes EASE™ Data – 3-D polar plots.

Independent Data Acquisition and Verification

All data for SoundTube speakers are independently collected and verified by NWAALabs (www.nwaalabs.com) using their proprietary MACH testing system. All data are collected and analyzed according to ASTM, ISO and AES standards using EASERA, TEF and MLSSA. Full balloon data including both phase and magnitude is compiled into a variety of formats including EASE 4.x, GLL and CLF.

Architectural Specifications

The subwoofer shall consist of one 254 mm (10 in.) low-frequency transducer installed in a 12.9-liter ported enclosure. The transducer shall have a polypropylene cone with a butyl rubber surround. The speaker shall be the CM1001d-T (with 150-watt transformer).

Performance specifications of a typical production unit shall be as follows: Usable frequency range shall extend from 41 Hz - 224 Hz, -10 dB. Maximum continuous output at 1 meter shall be at least 114 dB. The CM1001d-T subwoofer shall include a selectable 25-, 70.7-, 100-volt and voice-coil-direct tap switch. Rated power capacity of the components and network shall be at least 150 watts continuous RMS and conform to EIA-426-B testing.

The backcan shall be constructed of galvanized steel with a UL 94 V(0) flame-rated ABS baffle. The grille shall be constructed of powder-coated steel. Packaged complete with UL-rated conduit cover plate, color-coded tile bridge (to match color-coded backcan label), grille, and paint shield, the integrated CM1001d-T in-ceiling subwoofer is engineered for high performance and rapid installation in plenum spaces. The CM1001d-T incorporates a secondary attachment point for added security, or code satisfaction where required.

Installation for the CM1001d-T shall be by two-screw, blind-mount, constant-tension, fixed-winged assembly and shall attach to ceiling thicknesses ranging from 6.4 mm (0.25 in.) to 42.9 mm (1.69 in.). The external wiring input connector shall be a four-pin, 5 mm Euroblock for 4 ohm or distributed systems and shall accept from 10 – 22-gauge wire.

The CM1001d-T is factory preset to the 150-watt setting in the 70.7-volt operating mode, with a tap switch located on the front

baffle. The system shall be the SoundTube CM1001d-T for low- and high-impedance applications.

SoundTube Entertainment

6430 Business Park Loop Road
Park City, Utah 84098
Phone 435.647.9555
Fax 435.647.9666
Toll Free 800.647.TUBE
www.soundtube.com

All SoundTube products come with a 5-year limited warranty.

Graphs and Plots

Frequency Response

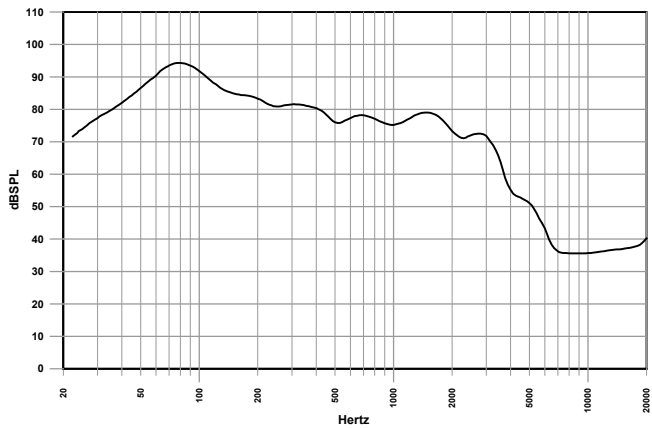

Phase/Impedance Response

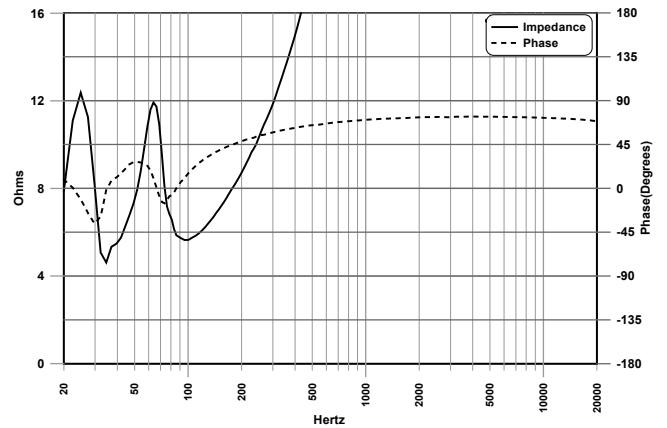

Vertical Beamwidth

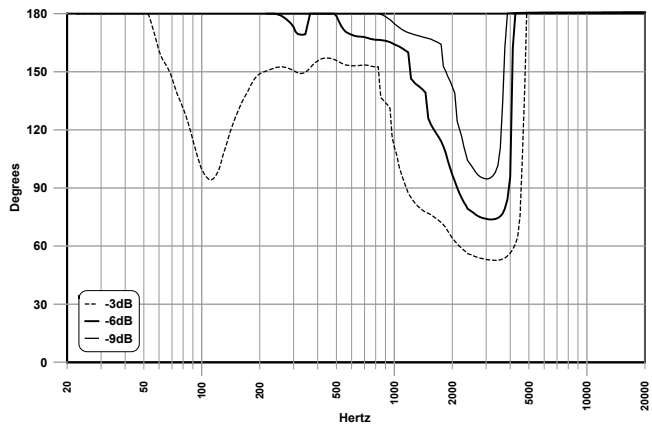

Directivity Index (DI)

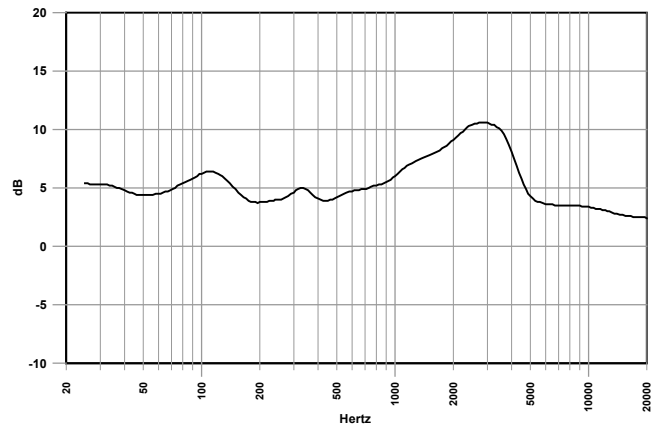

CM1001d-T

In-Ceiling Subwoofer
Technical Information for System Engineers



SOUNDTUBE
ENTERTAINMENT

Polar Plots

40 Hz

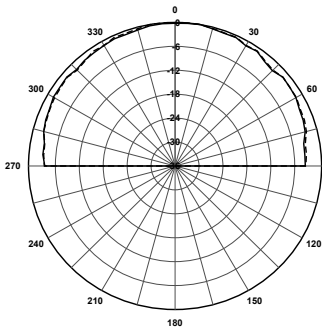

50 Hz

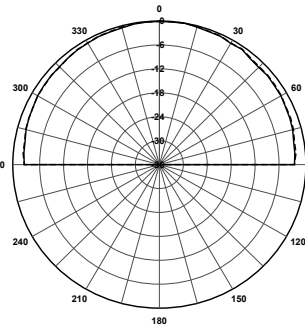

63 Hz

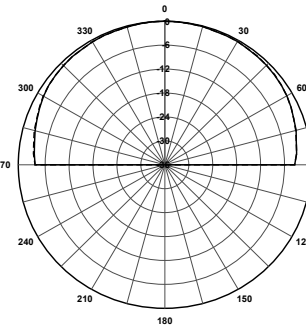

80 Hz

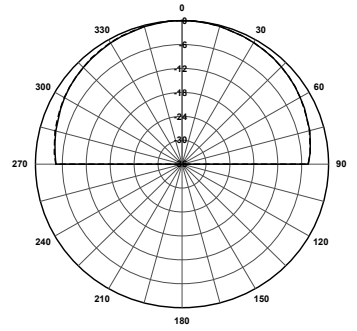

100 Hz

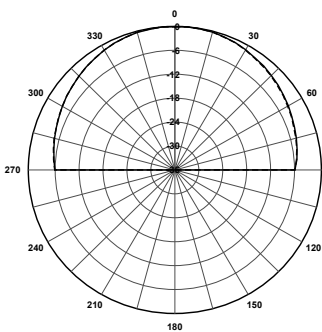

125 Hz

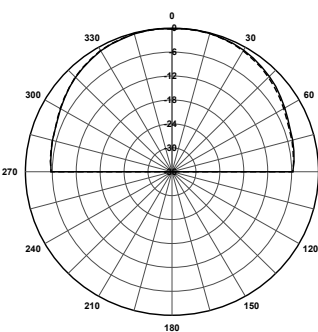

250 Hz

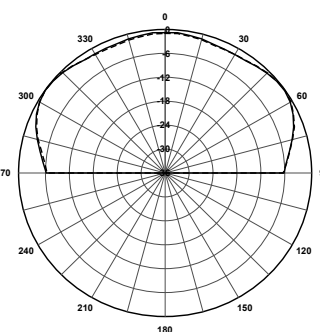

Technical data, EASE™ plots, SoundTubeSPEC™ software & product downloads available at www.soundtube.com

Mechanical Drawings

Side

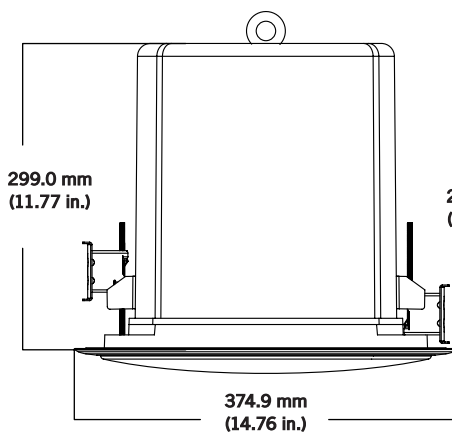

Top

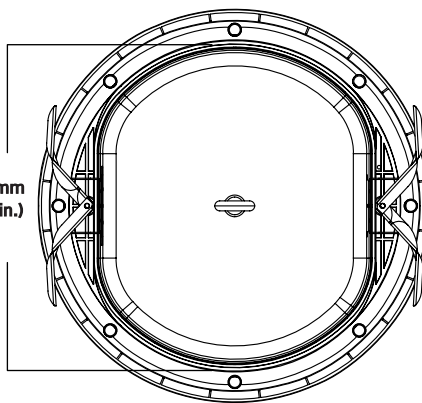

Included Accessories



Suspension Cable & Hardware

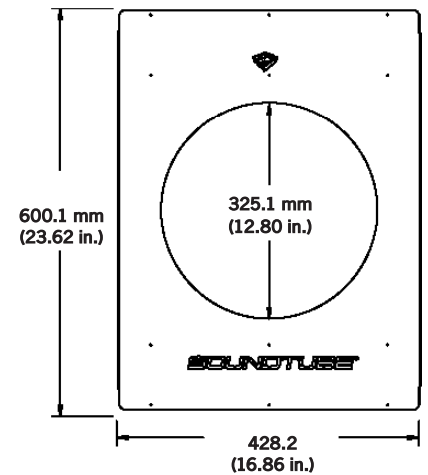

Tile Bridge

Optional Accessories

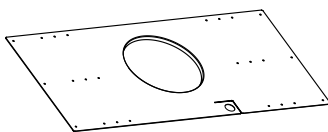

Pre-Construction Bracket (AC-CM8-PCB)

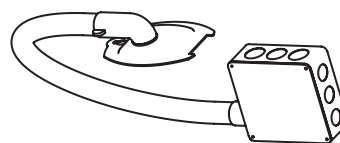

Junction Box (AC-CMi-JBOX)

SoundTube Entertainment manufactures a complete line of speakers for:
Open-Ceiling • In-Ceiling • Surface-Mount • Outdoor • Sound-Focusing

All SoundTube products are designed and engineered in the USA.