



Specifications: CM690i

System Type	6.5-inch, coax, in-ceiling, high-SPL, ported (66-watt transformer for 25/70.7/100-volt or voice coil direct)
Impedance (nominal) ¹	8 ohm
Sensitivity dB @ 2.83 V / 1 m	91.5 dB
Sensitivity dB @ 1 W / 1 m ²	91.5 dB
Frequency Response (-3 dB) ³	73 Hz - 22 kHz
Frequency Response (-10 dB) ³	62 Hz - 22 kHz
Max. Program Power ⁴	200 W
Max. Continuous Power RMS ⁵	100 W
Max. Power SPL @ 1 m ⁶	111.5 dB
Coverage Angle (-6 dB @ 2 kHz)	170°
Coverage Angle (-6 dB @ 10 kHz)	95°
Coverage Angle (averaged from 2 to 10 kHz)	100°
Directivity Factor (Q)	3.8 (averaged 100Hz - 10kHz); 4.6 (2 kHz)
Directivity Index (DI)	5.8 dB (averaged 100Hz - 10kHz); 5.8 dB (2 kHz)
Tap Selector	Six-position rotary switch with voice coil direct
Transducer - Low-Frequency Driver	165 mm (6.5 in.) treated fiber cone, cloth surround
Transducer - High-Frequency Driver	36 mm (1.42 in.) titanium compression driver with waveguide
Low-Frequency Voice Coil	34 mm (1.34 in.)
Crossover Frequency	3.0 kHz
Network Type: Low Pass	18 dB per octave, 3rd order
Network Type: High Pass	18 dB per octave, 3rd order
Enclosure Material	Drawn aluminum backcan with ABS baffle
Motor-board	Cast aluminum
Grille	Steel with powder-coat finish
Inputs	Four-pin, 5 mm Euroblock for individual or daisy chain connection
Colors	Black or white
Backcan Diameter	296.7 mm (11.68 in.)
Backcan Height	201.7 mm (7.94 in.)
Visible Diameter	374.9 mm (14.76 in.)
Visible Height	27.4 mm (1.08 in.)
Mounting Hole Diameter	323.9 mm (12.75 in.)
Min / Max Ceiling Thickness	6.4 mm (0.25 in.) - 42.9 mm (1.69 in.)
Weight	5.8 kg (12.8 lbs.)
Shipping Weight	18.0 kg (39.6 lbs.)
Packaging	Two per box
Included Accessories	Tile bridge, conduit plate, Euroblock connector and installation aid
Optional Accessories	Pre-construction bracket (AC-CM6-PCB), junction box (AC-CM6-JBOX)
Regulatory - UL	UL 1480 and 2043 approved
Regulatory - CE	Approved

Transformer Taps

70.7 V Output	100 V Output	25 V Output
66 W 109.5 dB	66 W 109.5 dB	5 W 98.5 dB
35 W 107.0 dB	35 W 107.0 dB	2.5 W 95.5 dB
19 W 104.5 dB	19 W 104.5 dB	1.25 W 92.5 dB
10 W 101.5 dB	10 W 101.5 dB	0.75 W 90.5 dB
5 W 98.5 dB		

¹ Impedance listed per IEC 60268-5 with a minimum less than 80% the nominal impedance

² 1 W 1 m sensitivity determined using nominal impedance

³ Frequency response measured in half or full space as dictated by speaker mounting configuration

⁴ Max program power is 3 dB above max continuous power

⁵ Continuous power rating, EIA-426-B test

⁶ Max output based on max continuous power

Key Features

- Patented BroadBeamHP® waveguide technology delivers a consistent dispersion pattern for maximum intelligibility and edge-to-edge coverage (up to 8 kHz, independently verified).
- A 66-watt transformer and high output (111.5 dB) for the sound reinforcement and PA markets.
- Easy-access six-position selectable tap switch for 25-, 70.7- and 100-volt applications with voice coil direct position simplifies ordering and inventory tracking.
- One 165 mm (6.5 in.) treated fiber driver and one compression driver with a 25.4 mm (1.0 in.) exit mounted to a proprietary cast-aluminum M6™ baffle and heat sink.
- Average sensitivity of 91.5 dB offers high-output capabilities and reduced amplification costs.
- Separate tool-free magnetic grille and bezel assembly with integrated safety/seismic cable for ease of install and in-field painting.
- Steel grille with protective powder-coated finish for lasting durability.
- Rapid-installation, blind-mount, fixed-wing mounting mechanism with constant-tension design affixes to ceiling thicknesses ranging from 6.4 mm (0.25 in.) to 42.9 mm (1.69 in.).
- UL 1480 and 2043 approved.
- Included accessories: Tile bridge, conduit plate, Euroblock connector and paint mask/installation aid.
- Optional accessories: Color-coded (purple) pre-construction bracket, junction box.
- High-quality black or white paint finish.

Description

The CM690i is a premium 6.5 inch, two-way, in-ceiling, high-efficiency, high-SPL loudspeaker for distributed or 8 ohm applications. The CM690i incorporates a dedicated 6.5 inch treated fiber driver and high-power compression transducer with a BroadBeamHP® waveguide to deliver a consistent dispersion pattern and superb intelligibility for the foreground music, sound reinforcement and PA markets. The CM690i incorporates a 66-watt transformer with a six-position tap switch with a voice coil direct position. Mounting hardware and tile bridge are included and feature a fast and secure constant-tension fixed-wing mounting system.



Applications

Engineered for installations requiring full-range background and foreground music plus paging, the CM690i delivers a smooth and even coverage pattern. Ideal for casinos, convention centers, warehouses, nightclubs, gyms, aerobic rooms, airports, super stores, arenas, theme parks, transportation hubs, shipping centers, stadiums, and other high-SPL or long-throw applications.

For applications where additional bass is required, SoundTube's CM1001d-T 10-inch subwoofer provides low-end response down to 41 Hz.

BroadBeamHP[®] Wide Dispersion Technology

SoundTube's proprietary BroadBeamHP[®] technology incorporates a high-frequency compression driver with a 1-inch exit mated to a treated fiber woofer. BroadBeamHP[®] technology delivers a consistent dispersion pattern across the upper registers of the frequency spectrum (up to 10 kHz, independently verified). The result is an audio system with better edge-to-edge coverage, reduced power needs, shorter installation time and cost savings on shipping and labor.

Patented SoundTube Technologies

SoundTube Entertainment and the MSE Audio Group constantly develop new technologies which enhance audio product performance. SoundTube Entertainment innovations are protected by multiple U.S. and international patents, which explicitly cover SoundTube dome, enclosure and dispersion technologies. The MSE Audio Group actively defends its patents in order to protect SoundTube resellers and end-users.

Technical Data and Specification Tools

Technical Data

SoundTube Entertainment strives to provide complete and effective technical information and data to dealers, engineers and designers. All data are available from SoundTube Entertainment or at www.soundtube.com.

Technical data and downloads include:

EASE[™] data – 3-D polar plots.

EASE[™] Address – 2-D modeling for distributed systems

Autodesk[®] Revit[®] software

Tech Sheets – Technical information and architectural specs for system engineers

SoundTubeSPEC[™] – Proprietary speaker placement software

Acquisition and Verification

All data for SoundTube speakers are independently collected from and verified by NWAALabs (www.nwaalabs.com) using their proprietary MACH testing system. All data are collected and analyzed according to ASTM, ISO and AES standards using EASERA, TEF and MLSSA. Full balloon data including both phase and magnitude is compiled into a variety of formats including EASE 4.x, GLL and CLF.

Architectural Specifications

The loudspeaker shall consist of a 165 mm (6.5 in.) low-frequency transducer and a high-frequency transducer with a 25.4 mm (1.0 in.) exit and a frequency-dividing network installed in a ported enclosure. The low-frequency voice coil diameter shall be 35 mm (1.38 in.).

The performance specifications of a typical production unit shall be as follows: Useable frequency response shall extend from 62 Hz – 22 kHz (-10 dB). Measured sensitivity (2.83-volt input, 1 meter) shall be at least 91.5 dB. The speaker shall have a nominal impedance of 8 ohms. The speaker shall be available for 25-, 70.7- and 100-volt modes and shall include a six-position tap switch with a voice coil direct position. The frequency-dividing network shall have a crossover frequency of 3 kHz with a slope of 18 dB per octave (3rd order). Rated power capacity shall be at least 100 watts continuous (RMS), and conform to EIA-426-B testing. Maximum continuous output at 1 meter shall be 111.5 dB.

The low-frequency transducer shall have a treated fiber cone and cloth surround.

Installation for the CM690i shall be by two-screw, blind-mount, constant-tension winged assembly and shall attach to ceiling thicknesses ranging from 6.4 mm (0.25

in.) to 42.9 mm (1.69 in.). The external wiring input connector shall be a four-pin, 5 mm Euroblock connector for 8 ohm or distributed systems and shall accept from 10 – 22-gauge wire. The maximum backcan dimension shall be no more than 201.7 mm (7.94 in.) in height by 296.7 mm (11.68 in.) in diameter. The maximum visible dimensions shall be no more than 275 mm (1.08 in.) in height by 375 mm (14.76 in.) in diameter. The backcan shall be constructed of aluminum.

The system shall include a 16-gauge painted steel support backing plate (tile bridge) to reinforce the ceiling material and tile support rails. The maximum tile bridge dimensions shall be no more than 600.1 mm (23.62 in.) in length by 428.2 mm (16.86 in.) in width and 10.4 mm (0.41 in.) in height with a 325.1 mm (12.80 in.) cutout for speaker mounting.

The grille shall be constructed of powder-coated steel with an ABS bezel. The affixed grille and bezel shall be mounted to the speaker enclosure (backcan) via magnetic attachment and included safety leash. Also included is a paint mask/installation aid for in-field painting (also serves as a handhold during mounting).

The CM690i has an optional color-coded (purple) pre-construction bracket (AC-CM6-PCB) that shall be compatible with an optional junction box (AC-CMi-JBOX). A 2-foot, 18-gauge wire whip and Euroblock connector shall be included with the junction box. The maximum dimensions of the pre-construction bracket shall be no more than 635 mm (25.0 in.) in length by 457.2 mm (18.0 in.) in width and 127 mm (5.0 in.) in height (includes affixed junction box) with a 326.1 (12.85 in.) cutout for speaker mounting.

The system shall be the SoundTube CM690i with mounting hardware for both low- and high-impedance applications.

SoundTube Entertainment

6430 North Business Park Loop
Park City, Utah 84098
Phone 435.647.9555
Fax 435.647.9666
Toll Free 800.647.TUBE
www.soundtube.com

All SoundTube products come with a 5-year limited warranty.

Graphs and Plots

Frequency Response

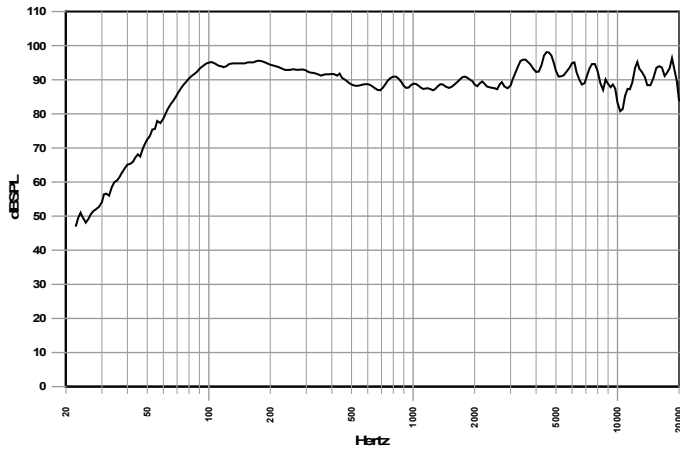

Phase/Impedance Response

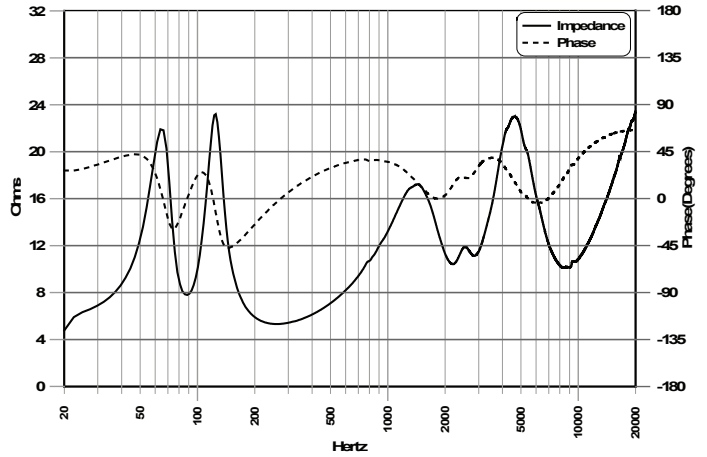

Vertical Beamwidth (-6 dB)

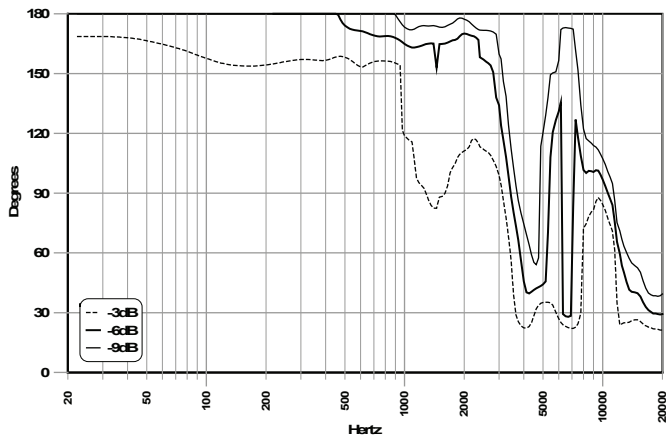

Directivity Index (DI)

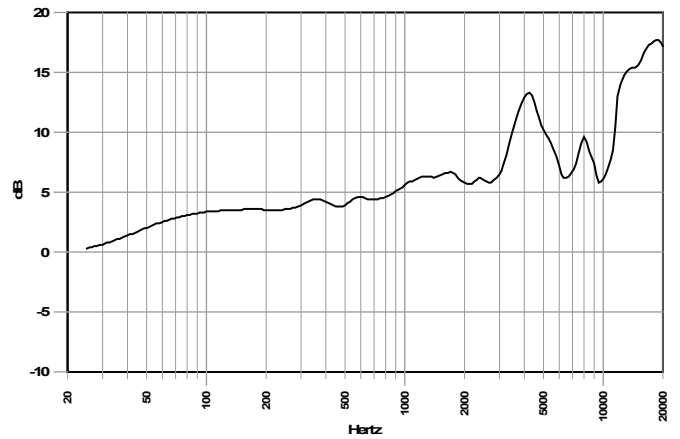



Polar Plots

— Horizontal
 - - - Vertical

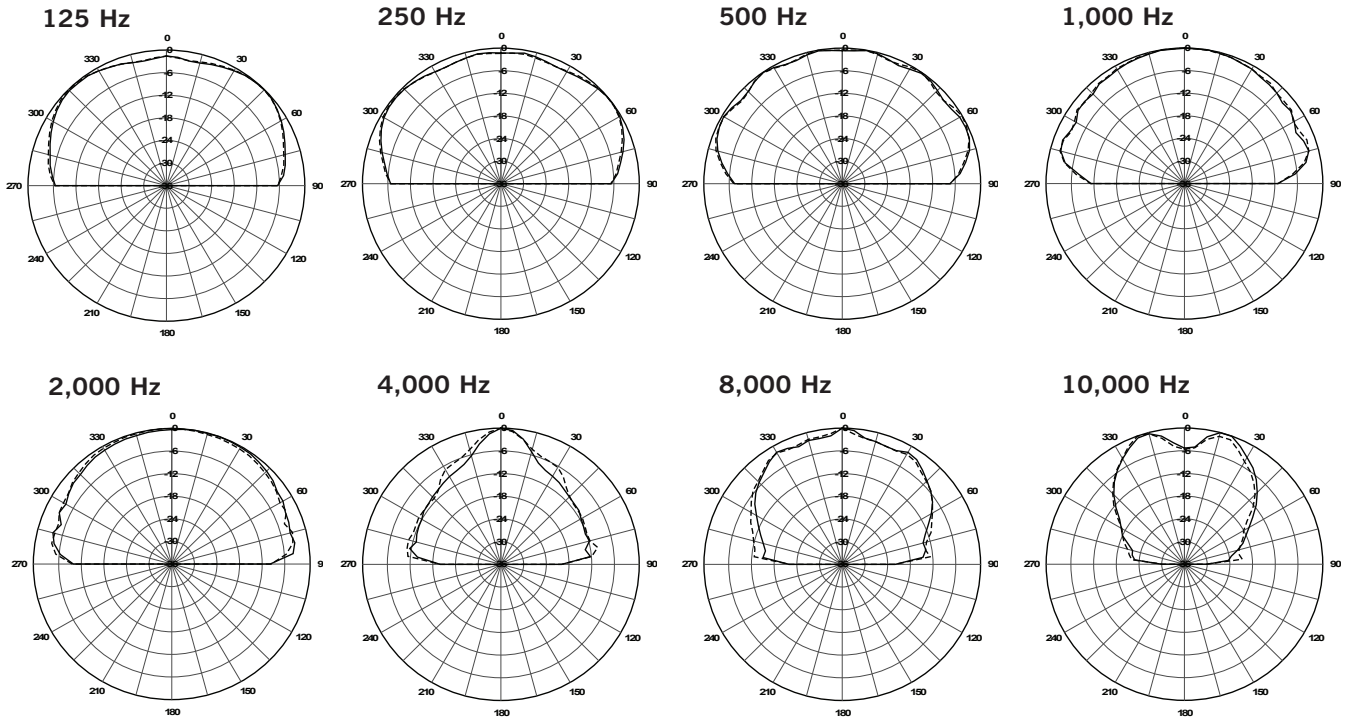

Technical data, EASE™ plots, SoundTubeSPEC™ software and product downloads available at www.soundtube.com

Mechanical Drawings

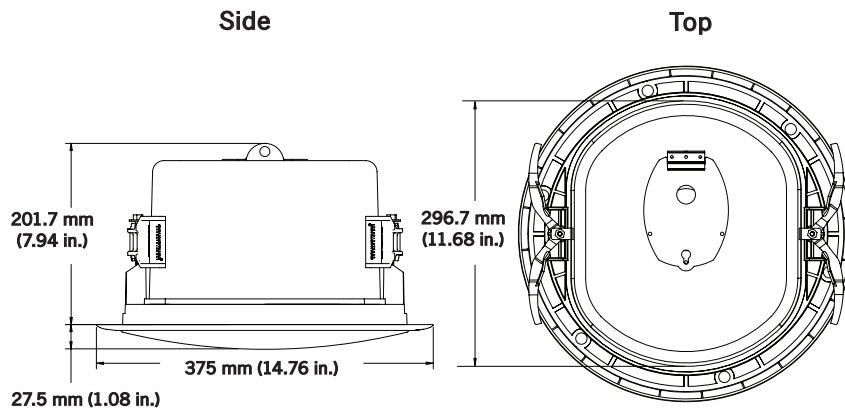

Minimum/Maximum Ceiling Thickness

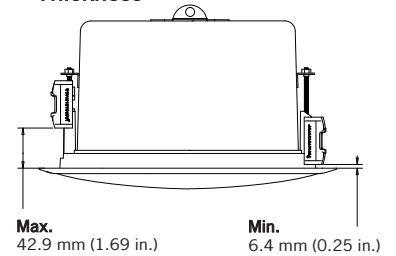

Included Accessories

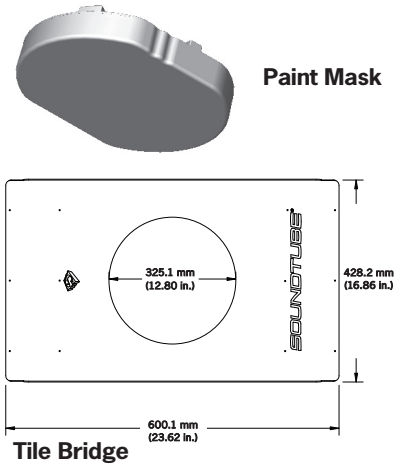

Optional Accessories

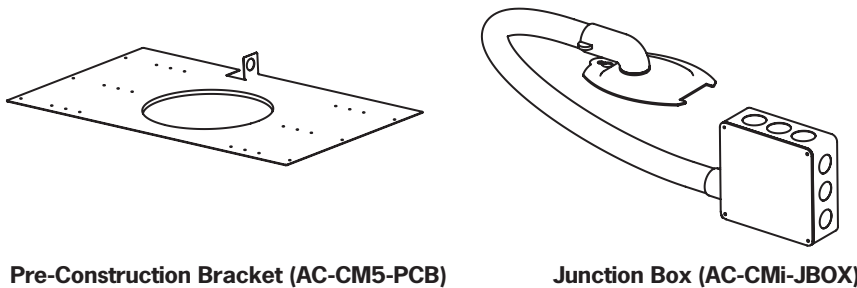

SoundTube Entertainment manufactures a complete line of speakers for:
Open-Ceiling • In-Ceiling • Surface-Mount • Outdoor • Sound-Focusing

All SoundTube products are designed and engineered in the USA.